

Warnings

- Using the equipment without following the manufacturer's instructions may affect the device's safety requirements. To ensure that the device operates correctly, only probes supplied by AKO should be used.
- The unit must be installed in a location protected from vibrations, water and corrosive gases, where the ambient temperature does not exceed that shown in the technical data.
- To ensure a correct reading, the probe must be situated in a location without any external heat influences except for the temperature which is being measured or controlled.
- The power supply circuit must be provided with a main switch rated at least 2 A, 230 V, located close to the equipment. The cables will enter through the back and should be type H05VV-F or H05V-K.
- The gauge will depend on local regulations, but should in no case be less than 1 mm².
- Connecting wires for the relay contacts should be sized 2.5 mm².
- Between -40 °C and +20 °C, if the probe NTC is prolonged till 1.000 m with a minimum of cable 0,5 mm², the maximum deviation will be of 0,25 °C (extension cable for probe ref. **AKO-15586**)

NOTE: Equipment not compatible with **AKO-14917** (external communication module) and **AKO-14918** (programming key)

Installation

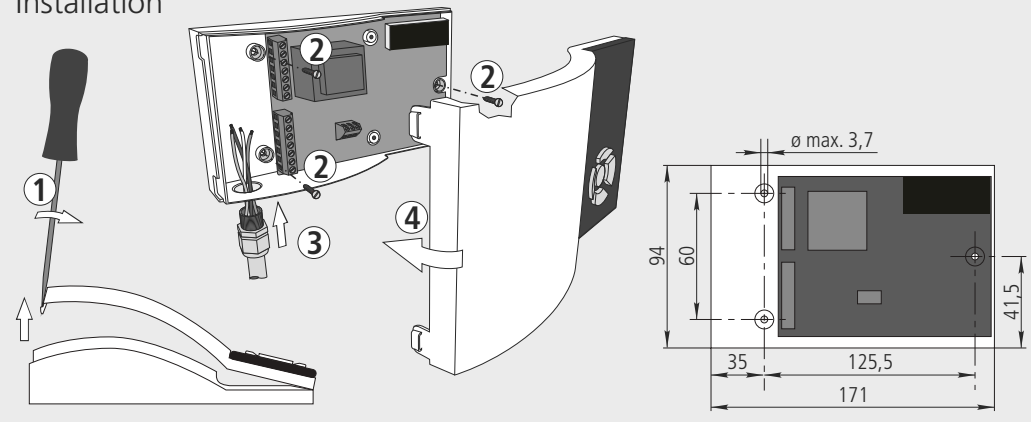

Operation

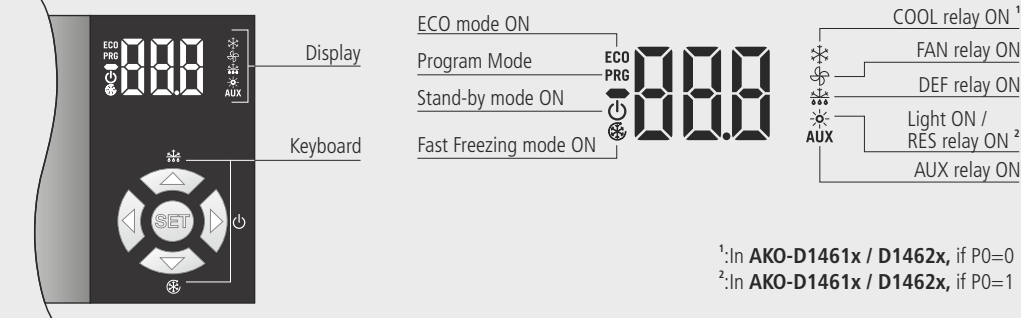

¹: In AKO-D1461x / D1462x, if P0=0

²: In AKO-D1461x / D1462x, if P0=1

- Press for 5 seconds, allows changing the set point (SP). (Not available in thermometers). Pressing for 10 seconds goes to the programming menu. In the programming menu, go to the level displayed or accept the new value while setting a parameter.
- Pressing for 5 seconds starts/stops defrosting. (Not available in thermometers). The programming menu, allows you to scroll through the various levels or, during the setting of a parameter, to change the value.
- Press for 5 seconds to start/stop Fast Freezing mode (rapid cooling). (Function available depending on the model). The programming menu, allows you to scroll through the various levels or, during the setting of a parameter, to change the value.
- Pressing for 5 seconds activates Standby mode, pressing for 2 seconds returns the equipment to normal mode. In Standby mode, the equipment performs no actions and only the indicator is displayed on the screen. In the programming menu, go to the level displayed.
- Pressing it for 1 second, activates or deactivates the cold room light (if P6=3). This function stays active although the unit is in the stand-by mode. (Function available depending on the model). In the programming menu, exit without saving parameter, return to previous level or exit programming.

Wiring

The probe and its cable should **NEVER** be installed in the same conduit as power, control or supply cables.

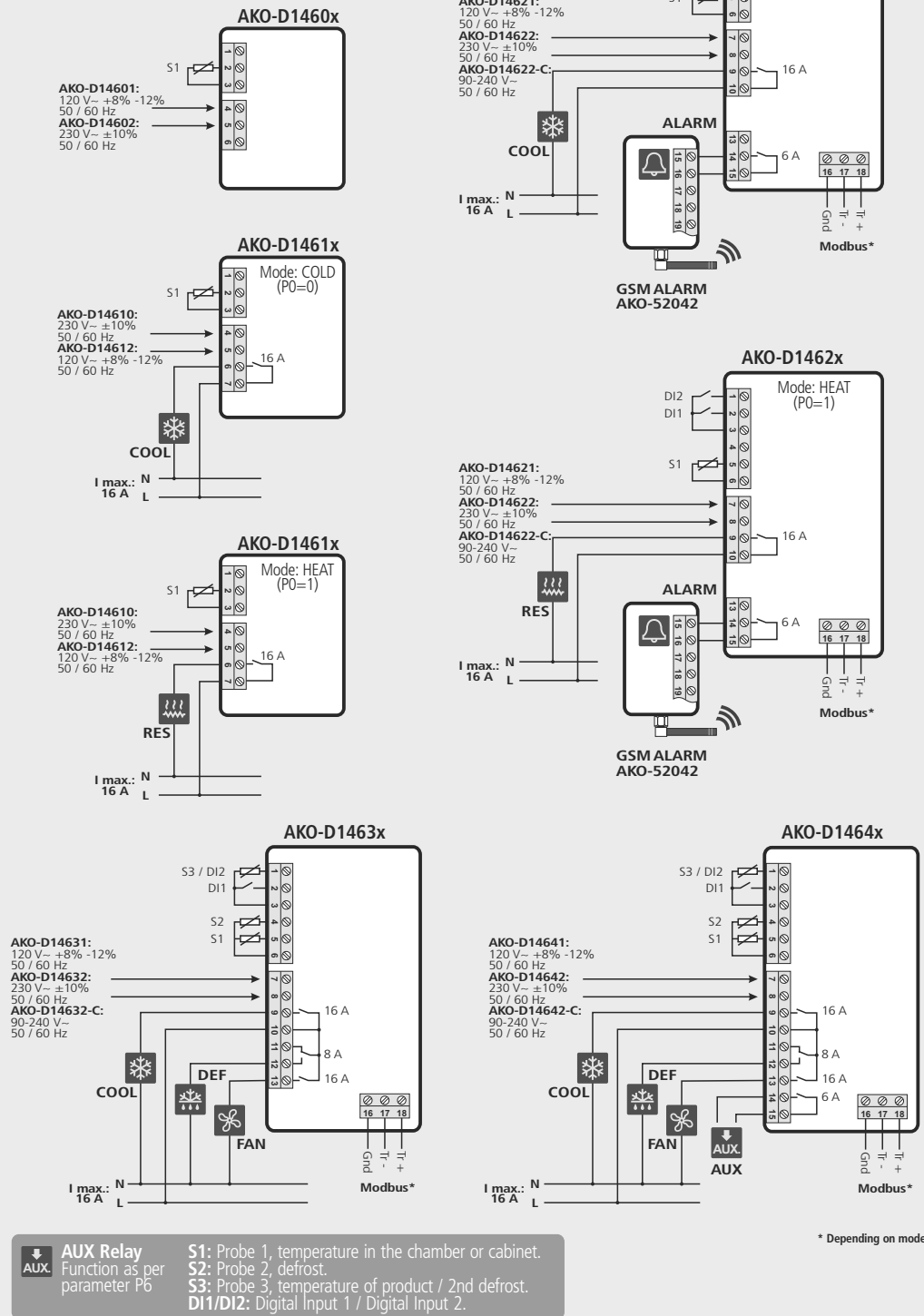

AUX Relay
Function as per parameter P6

S1: Probe 1, temperature in the chamber or cabinet.
S2: Probe 2, defrost.
S3: Probe 3, temperature of product / 2nd defrost.
DI1/DI2: Digital Input 1 / Digital Input 2.

* Depending on model

Start-up

AKO-D1461x / AKO-D1462x

On power-up, the equipment will start up in Wizard mode (In1 / 1 flashing), press ▲ or ▼ to select the most appropriate application and press SET.

- 1: Chilling 2: AC 3: Heat/Incubators

The wizard will configure the parameters of the equipment for the chosen application (see table).

	WIZARD			
	SP	d0	d1	P0
In1=1: Chilling	0	6	20	0
In1=2: AC	21	0	0	0
In1=3: Heat/Incubators	37	-	-	1

AKO-D1463x / AKO-D1464x

On power-up, the equipment will start up in Wizard mode (In1 / 1 flashing), press ▲ or ▼ to select the most appropriate application and press SET.

- 1: Chilling 2: Frozen 3: Fruits and vegetables
4: Fresh fish 5: Soft Drinks 6: Bottle racks
7: AC

The wizard will configure the parameters of the equipment for the chosen application (see table).

	WIZARD				
	SP	d0	d1	F0	F3
In1=1: Chilling	2	4	20	8	1
In1=2: Frozen	-18	4	20	0	0
In1=3: Fruits and Vegetables	10	4	20	30	1
In1=4: Fresh fish	0	4	20	8	1
In1=5: Soft Drinks	3	24	20	8	1
In1=6: Bottle racks	12	24	20	30	1
In1=7: AC	21	96	0	99	1

WARNING: The default parameters by type of application have been defined for the most common applications. Check that these parameters are suitable for your installation.

AKO GB 1461H032 Ed.02

Installation instructions



AKO-D1460x **AKO-D1461x** **AKO-D1462x**
AKO-D1463x **AKO-D1464x** **AKO-D146xx-C**

