

12950014
X001-EU14

标记 Mark	处数 QTY	更改文件号/内容	签字/ Sign	日期/ Date

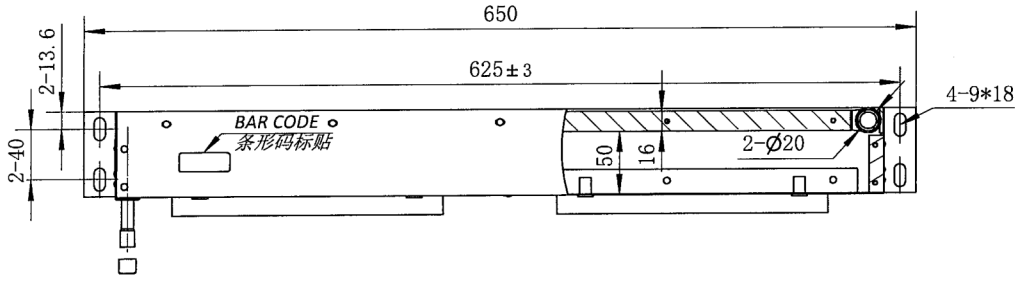

TECHNICAL REQUIREMENT:
 1.翅片FPI=12.7.
 FPI=12.7;
 2.扁管规格:16*1.3*16,材料:AA3102;
 TUBE:16*1.3*16, Material : AA3102;
 3.翅片规格 : 0.08*16 , 高度 : 8.1 ;
 FIN:0.08*16, FIN HEIGHT:8.1;
 4.进出口管为铜管 ;
 INLET AND OUTLET PIPES ARE COPPER TUBES;

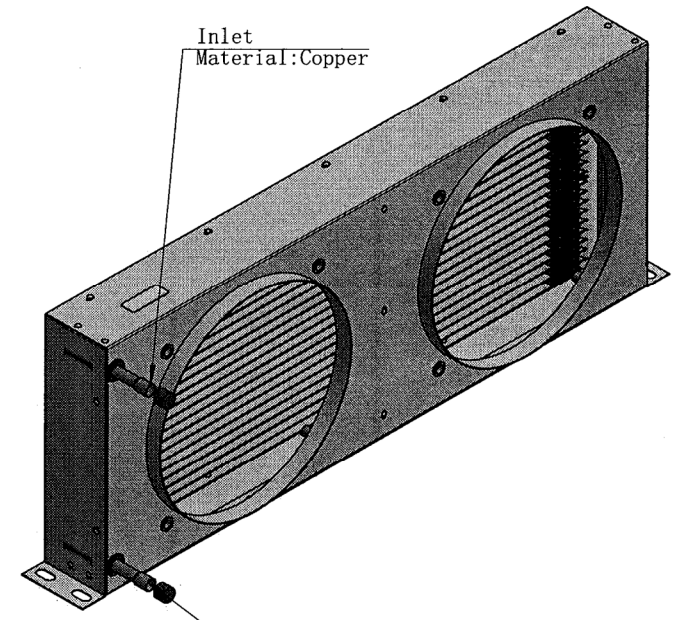
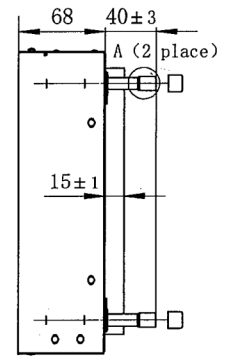
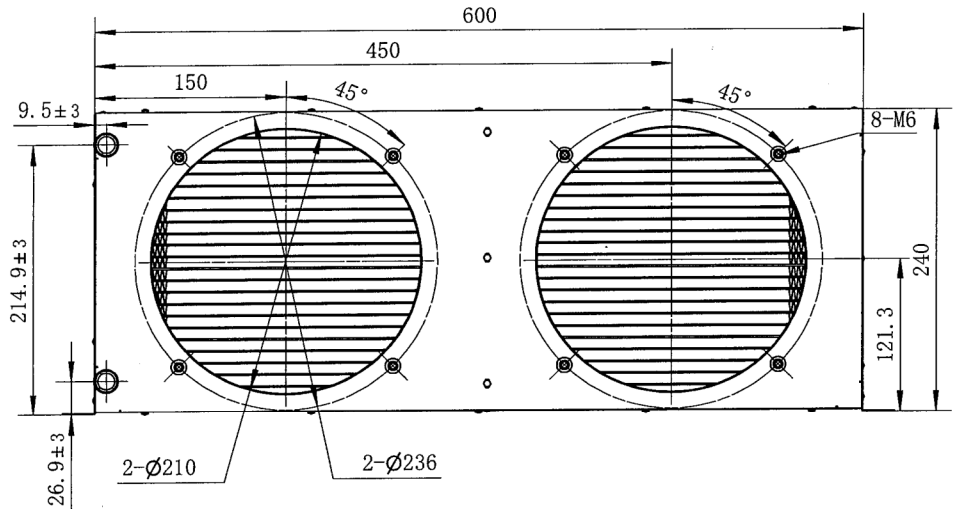
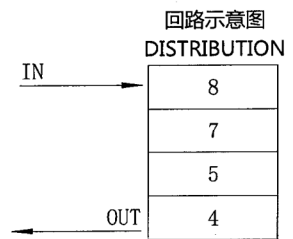
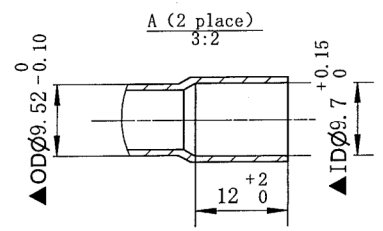

图纸客户确认栏
Customer Approve

签字
Sign *穆丹丹*

未注线性尺寸公差/Unmarked Linear Tolerance				
≤6	>6~30	>30~120	>120~400	>400~1000
±0.1	±1	±1.5	±2	±3
±0.1	±1	±1.5	±2	±3
±0.1	±1	±1.5	±2	±3
±0.1	±1	±1.5	±2	±3
未注角度公差/Unmarked Angle Tolerance				
直角/Right angle	±2°	其它角/Other angle	±3°	
设计/DRN	沈通	标准化/Standardize		
校对/CHK	<i>胡琛</i>	批准/APR	<i>穆丹丹</i>	
审核/ENG	<i>胡琛</i>	日期/Date	<i>2014.11.14</i>	
工艺/MFG	<i>胡琛</i>	日期/Date	<i>2014.11.14</i>	

微通道冷凝器/Condenser		1st Angle 一角法
比例/ Scale	1:4	
版本/ Rev.	00	
页码/ Page	第 1 页	共 1 页
Page	1	Total 1
Sanhua (HangZhou) Micro		X001-EU14
Channel Heat Exchanger Co., LTI		12950014