

# MicroBlue™



**3** year warranty

## Performance

17dba

Max flow	Max head	Max suction lift
5 litres/hour	5 metres	2 metres

With no additional silencing accessories required, not only is the MicroBlue™ a silent running pump but it can also be mounted in any orientation whilst operating both wet and dry continuously. The MicroBlue™ is a dual voltage pump which uses proven thermistor level sensing technology to remove the risk of stuck or sunken float switches.



## Sensing Options

MicroBlue™ pump available with:

Reservoir sensor	Ducting Kit	Fascia Kit
X85-001 (HLA PACK) X85-002 (FSA PACK)	X85-507 (HLA PACK)	T18-016

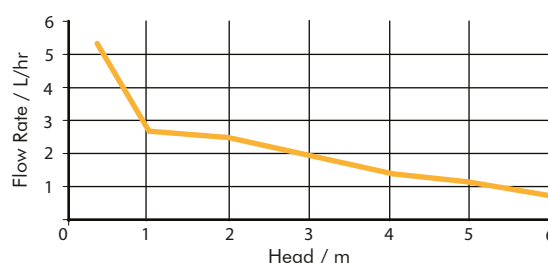

## Why BlueDiamond® ?



**Pumps Debris**

The MicroBlue™ is the only ductless pump on the market that can remove sediment/ debris with no need of filters or regular servicing intervals.



**No Silencing Devices**

Smooth flow rate from the MicroBlue™ eliminates the necessity for any pulsating free tubing and silencing devices.

## Dimensions (mm)

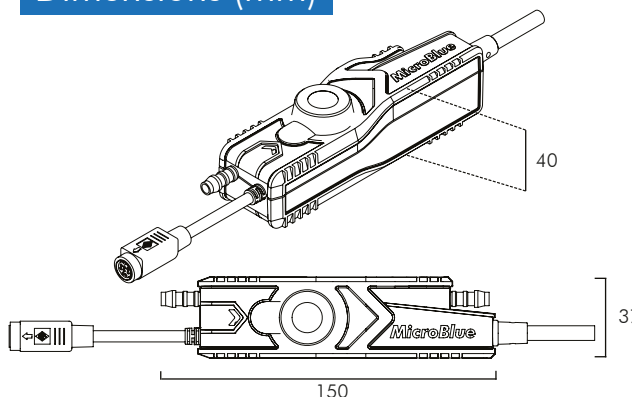

## Installation Options

The MicroBlue™ can be mounted in any orientation up to 2m away from the air conditioning unit.

- 1 Can be fitted inside casing
- 2 MicroBlue Fascia Kit
- 3 MicroBlue Ducting Kit
- 4 Mounted Inside Ceiling Cavity

